

# FITMENT INSTRUCTIONS

**Alu-Cab™**



## **Khaya To Ford Ranger (USA Spec) Short Bed (KH-BRKT-FR-USA)**

All rights reserved. No part of this document may be reproduced, translated, stored in a retrieval system, or transmitted, in any form or by any means, electronic, mechanical, photocopying, recording or otherwise, without prior written permission of the owner.

Review all instructions information carefully before installation.

Any damages, direct or incidental to the installer and/or property due to incorrect installation of any parts are the responsibility of the installer. Due to the various applications and fitment options available, the responsibility lies with the user to ensure all mounting points are secure and tight before every trip. If unsure, consult with your Distributor regarding the operations of our products.

Users are advised to be mindful of the load they are carrying and drive in accordance with road conditions.

**DISCLAIMER**

**Alu-Cab**

# **1. Khaya Fitment – Tools, Fasteners & Materials**

The tables below show the equipment, i.e. tools and fasteners required to mount the Khaya onto a short bed Ford Ranger (USA Spec). Note that this fitment requires an additional mounting kit: KH-BRKT-FR-USA

## **1.1 Tools & Items Required:**

<b>TOOLS</b>
Ratchet
Allen key
19mm Socket
19mm Ring Flat Spanner
17mm Socket
17mm Ring Flat Spanner
Drill and 12.5mm drill bit

## **1.2 Fasteners supplied (Main Khaya Mounting Kit):**

<b>ITEM</b>	<b>QUANTITY</b>
M12 Flat Washer	10 off
M12 Spring Washer	8 off
M12 Eye bolt	2 off
M12 Eye nut	4 off
M12 rigging screw	2 off
M12 Nyloc nut	6 off
M12 nut	2 off
M12x35 Hex Bolt	4 off
M10 D-shackle	8 off

## **1.3 Hardware Supplied (Main Khaya Mounting Kit):**

<b>ITEM</b>	<b>QUANTITY</b>
Spreader plates	2 off
Towbar plate	1 off
300mm chain	4 off
Rear mounting brackets	2 off

# 1.4 Hardware & Fasteners Supplied (KH-BKRT-FR-USA):

ITEM NO.	PART NUMBER	DESCRIPTION	QTY.
1	132-FORD-USA-FNT-MNT-01-00	FRONT MOUNT BRACKET (LH)	1
2	132-FORD-USA-FNT-MNT-02-00	FRONT MOUNT BRACKET (RH)	1
3	HEX-M8X20	HEX HEAD BOLT	8
4	FW-M8	FLAT WASHER	24
5	HEX-M8X25	HEX HEAD BOLT	8
6	NY-M8	NYLOC NUT	8

REV.	DESCRIPTION	ECO	DATE	APPROVED

<b>TOLEANCES TO ASSUME UNLESS INDICATED OTHERWISE</b> <small>UNLESS INDICATED OTHERWISE</small> <small>ALL DIMENSIONS ARE IN MILLIMETERS UNLESS OTHERWISE SPECIFIED</small>		<b>DESCRIPTION</b> KHAYA FRONT BRACKET KIT (FORD RANGER USA - SB) PRODUCT: KHAYA DRAWN BY: B NEDHAM DATE: 16.01.2020 THE INFORMATION CONTAINED WITHIN THIS DOCUMENT IS THE INTELLECTUAL PROPERTY OF ALU-CAB LTD	SHEET: A4 SCALE: 1:1 DRAWING NO: KH-BKRT-FR-USA	SHEET: 1 of 1 REV: 00
0.00 - 0.05 0.05 - 0.10 0.10 - 0.20 0.20 - 0.30 0.30 - 0.50 0.50 - 1.00 1.00 - 2.00	0.10 0.15 0.20 0.30 0.50 1.00 2.00		ALU-CAB (P.O. BOX 100) WILMINGTON, MA 01897 USA	



## WARNING

Always wear appropriate PPE ( Personal protection equipment) when fitting this product. Although the mounting kit is designed to be DIY, if you have any doubts or concerns, contact an accredited fitment centre to carry out the work. Alu-Cab will not be liable for any injury to persons, and/or damage to products and/or vehicles.

## 2. Front Fitment

Using the Ford Ranger SB (USA Spec) specific mounting kit (KH-BKRT-FR-USA), install the two front mounting brackets, as indicated below:



Mount the brackets on the LH and RH sides, making use of the four (4) factory mounting points either side, as indicated. Use the supplied M8X20 bolts, and M8 washers.

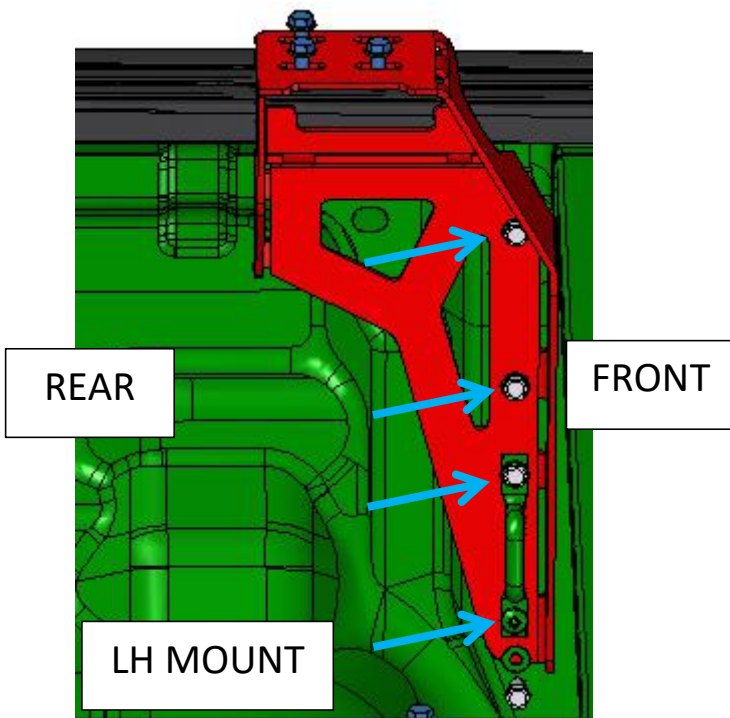

### 3. Fitting the Khaya

Fit the leg brackets to the Khaya and jack up about 50mm higher than the load bin floor. Then reverse in your vehicle. Try to align the Khaya central to the bed. Once the Khaya is against the load bin front you can begin to lower it.

Ensure that the front mounting locations, of the Khaya, align with the front mounting brackets, which were installed in the previous step. Once aligned, lower the Khaya, until it seats. Insert and tighten the supplied fasteners, as per the images below.

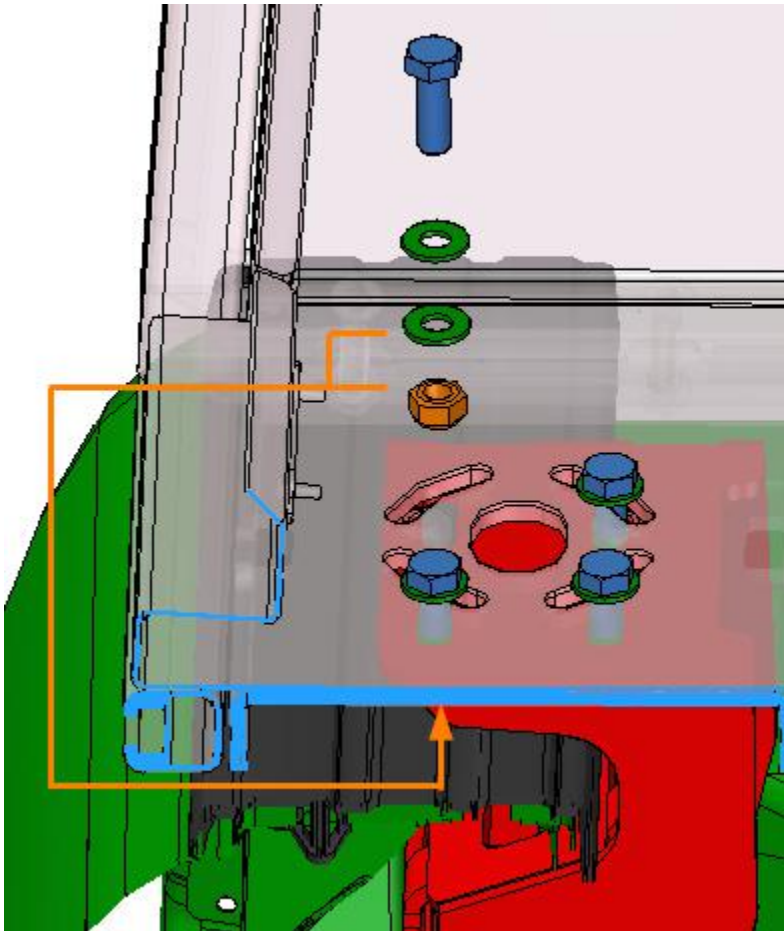

The nut and washer, that need to be located from the underside, are indicated above. The working space between the load bed walls, and the Khaya frame is very tight. It is advisable to use a 13mm ring spanner, and using a small piece of adhesive tape, locate the nut and washer in the ring spanner. This will ensure that it does not fall out, into the load bin, during installation.

## 4. Rear Fitment

The rear mounting brackets are pre-fitted to the Khaya. Remove the tow bar bolts and fit the tow bar plate supplied. Fit the two eye bolts and fasten with a washer and M12x35 hex bolt supplied. Tie down the camper with the RIGGING SCREW assembly as shown below.

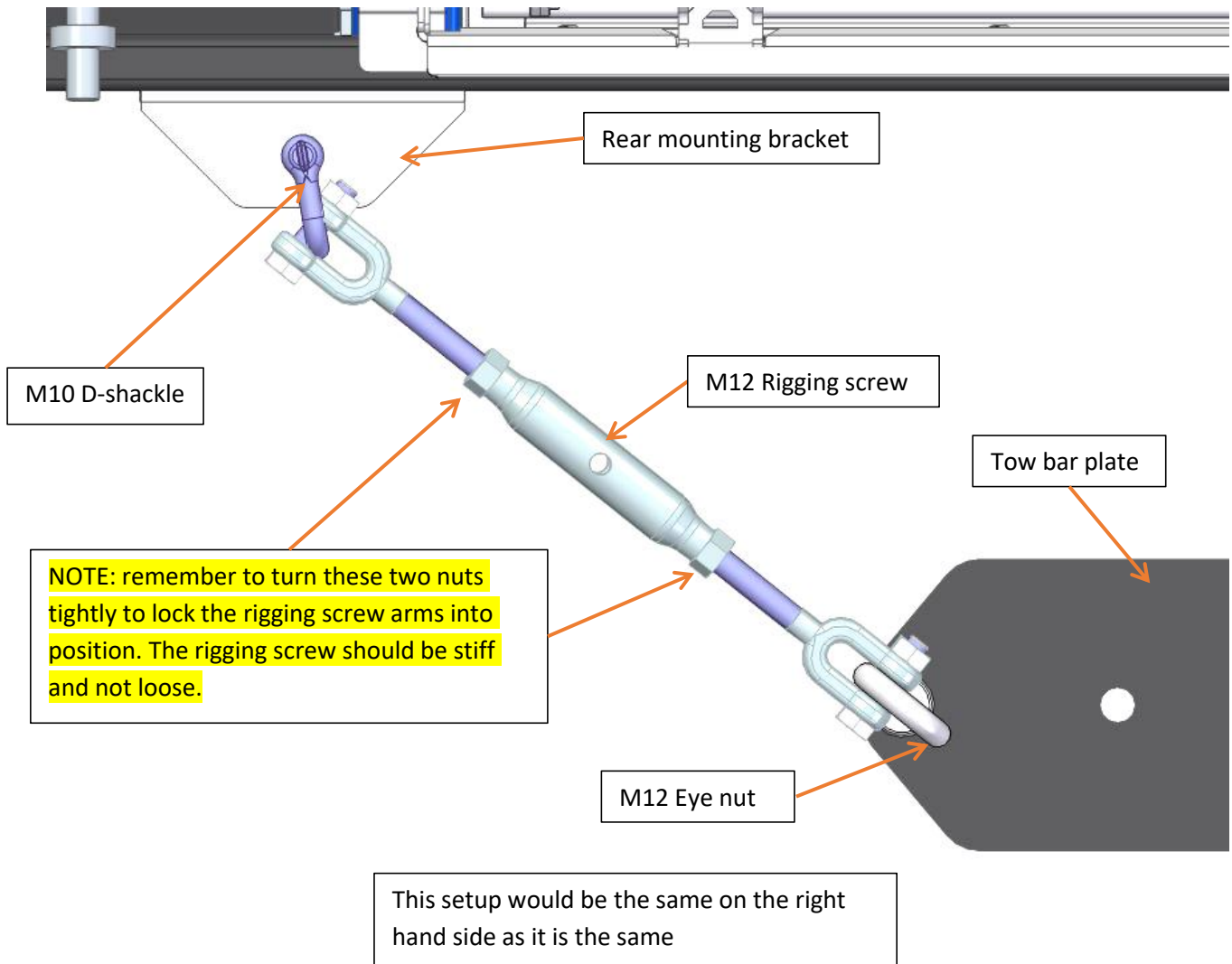

NB: In some cases there may be a metal chain in the rigging screw assembly to accommodate for Length variants.